

# TWIN

Ambienti

euROCRYOR  
eptarefrigeration

PURO STILE ITALIANO



## Product categories



Delicatessen



Dairy products



Pastries



Pre-packed fruit and vegetables



Fruit and Vegetables



Sandwiches



Drinks

## Technical features



Off-cycle defrost



Electric defrost



Ventilated



Incorporated condensing unit



Remote condensing unit



LED lighting



High efficiency fans

## Accessories

- REFRIGERATED STORAGE CL
- REFRIGERATED STORAGE FL
- PASTRY DRAWER
- FRONT BASKET / BOTTLE DISPLAY RACK
- PLEXIGLASS CLOSURE ON RAIL
- LOW MOBILE DIVIDER
- ANTI-MIST FRONT BAFFLE
- HOOKSREAR SUPPORT\*
- SHELF
- STEPPED DESK
- SLIDING MACHINE/SCALE HOLDER
- ROTATING PLATE
- BASKET RAIL WITH THREE TUBES
- PAPER HOLDER
- 360mm BACK-SHELF PAPER HOLDER
- DOUBLE PAPER HOLDER
- KNIVES HOLDER
- PAPER ROLL HOLDER
- SCALE HOLDER ON BRACKET
- PRICE TICKET STRIP
- ELECTRICAL SOCKETS
- POLYETHYLENE CUTTING BOARD
- NIGHT BLINDS
- FLOOR TUBULAR BUMPER RAIL
- BUMPER RAIL
- TUBULAR BUMPER RAIL ON CANOPY
- G-N PANS\*
- FISH TANKS
- ICE-CREAM SCOOP CLEANER
- ICE-CREAM TRAYS

\*supplied separately

Follow us on:      by Epta

www.eurocryor.com

# TWIN

Ambienti

**PURO STILE ITALIANO**

## Cross Sections

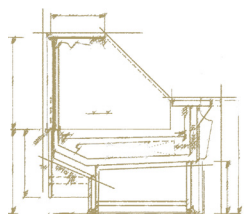
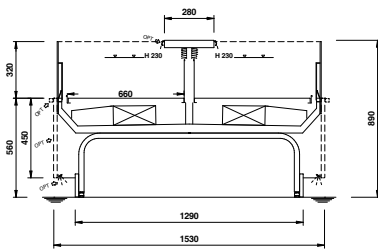
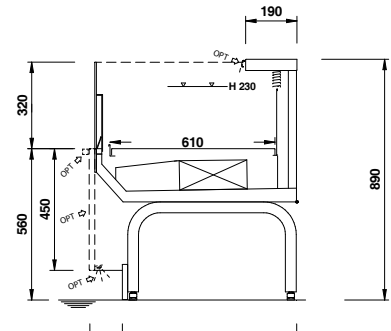
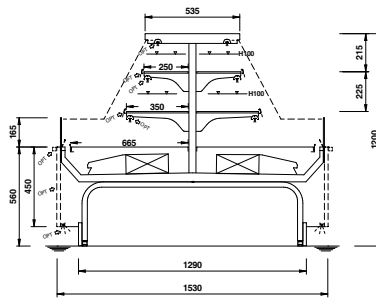
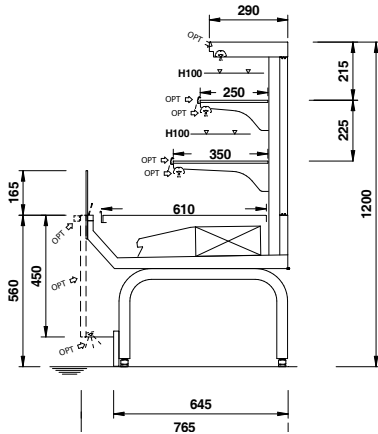

Fully customized solutions: design flexibility of shapes & sizes.  
Our team is at complete disposal for evaluating any different solutions  
in order to fulfill all your needs. Please write at [sales@eurocryor.it](mailto:sales@eurocryor.it)